



Moving Van Bodies



Premium Moving Bodies for Professional Movers

In continuous operation since 1945, U.S. Truck Body has been a leader in the trucking industry by designing, manufacturing, and distributing van bodies for commercial fleets, truck dealers, individuals, and truck leasing companies nationwide.





Quality starts from the ground up. We know that professional movers need van bodies that will hold up under heavy use, shifting loads, and specialized delivery demands. Bottom line – they have to last!

Side and Swing Doors

U.S. Truck Body swing doors set the standard for quality. We custom build all rear and side swing doors with the best material and workmanship so you can expect a *precise fit, positive closing, and long lasting quality.*



We start with **DuraPlate®**, the efficient, lightweight, and incredibly strong panel that provides exceptional resistance to damage, leaks, and corrosion. Our DuraPlate door panels are composed of 80,000 psi yield steel skins. The polyethylene core and the bond between the skins and core form an added barrier that won't deteriorate and is impervious to water. With no plywood construction, there is nothing to rot. Then we add stainless steel bar locks and latches, along with premium heavy-duty extruded aluminum hinges and stainless steel replaceable pins.



Peaks to Perfection



We've designed our peaks for maximum size and load capacity. On each side, heavy extruded aluminum rails are gusseted to steel logistic posts to form a full extension of each side. An FRP panel fits firmly into the side and front rails and is further supported from underneath with 2" x 3" aluminum cross members. The extruded aluminum radius corners tie together the front posts and panels to the side walls to complete one of the strongest peaks in the industry.

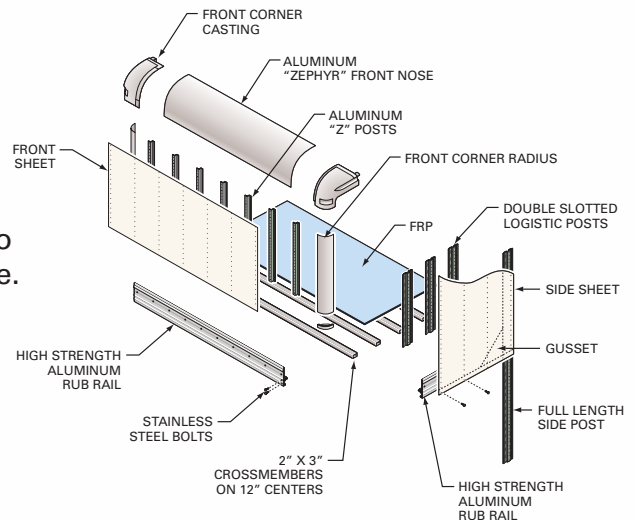

Roofs

Our unique two-piece roof / rail system is designed for strength and durability. Heavy-duty one piece translucent or aluminum sheeting is tension-fitted and bonded to 18 gauge galvanized steel anti-sag roof bows. Each roof bow is double riveted to the extruded high-strength aluminum alloy roof cove. This design not only increases structural integrity, it also means the roof can be easily replaced (if damaged) without disturbing the side wall structure.

For additional strength, we use a fuel-efficient "Zephyr" front nose and heavy-duty cast aluminum (not plastic) corners. The aerodynamic design reduces air resistance and helps deflect overhanging tree branches.

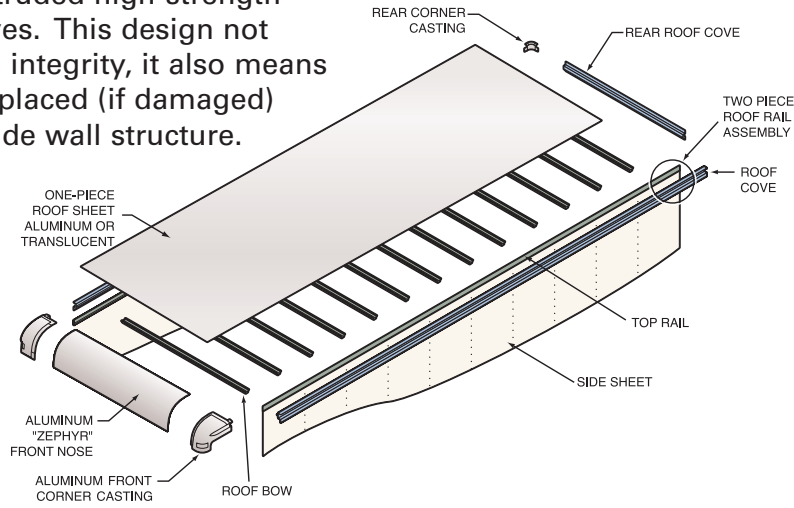

48" center lined or full width plywood lining is available as option

Floor / Side Structure

Crossmembers – 80,000 psi hi-tensile steel I-beams are double bolted at each end to heavy-duty extruded aluminum rub rails. Alternating crossmembers are gusseted to longitudinals, and steel wheel pans add support over the rear wheels. Double slotted galvanized steel logistic side posts are used on 24" (or optional 16") centers with 1/4" plywood panels recessed between the posts as our standard construction.

Finished Oak Hardwood Floor – Quality 1 1/8" thick laminated oak flooring is our standard moving van body floor, installed with two 5/16" countersunk screws per board at each crossmember. Each board is joined together with ship-lap joints, and an added crusher bead ensures a super-tight fit. Then the entire floor receives multiple coats of polyurethane varnish for lasting protection.

Screw holes are filled and sanded prior to varnishing as an option.

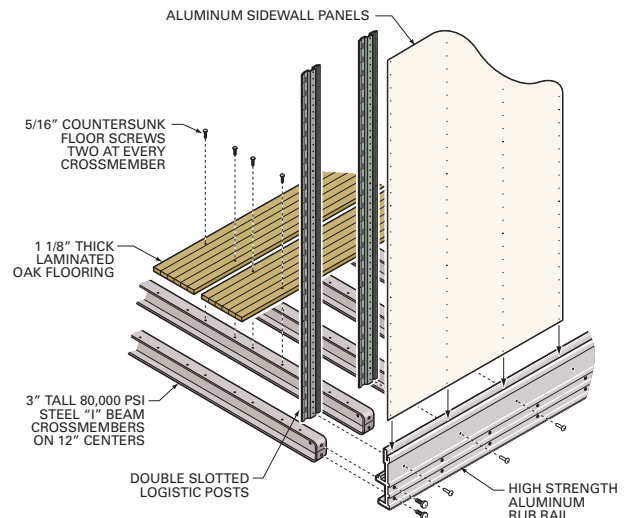

Rear Frame

To withstand the tough loading conditions of moving professionals, we build our frames with heavy-duty 11 gauge galvaneal steel and reinforce all internal and external stress points with steel plates (shown in yellow on the drawing). A tapered sill provides the proper water run-off. Stainless steel frames are also available as an option.

Assembling each U.S. Truck Body frame using a spinner jig allows welding to be done on a horizontal plane to ensure the best possible weld penetration.

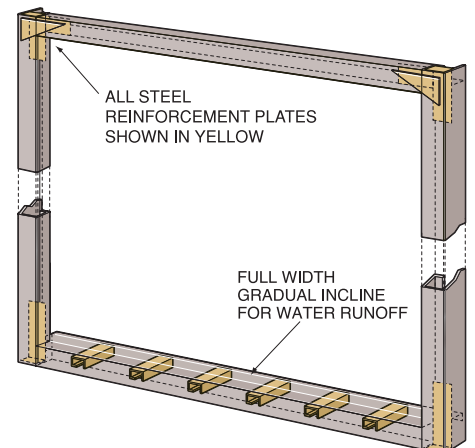



Moving Van Features

Front - Aerodynamic radius with heavy-duty corner castings (not fiberglass), 5" front corner radius utilizing 1/8" rugged aluminum extrusion.

Walls - Aluminum (.040 in.) panels, pre-painted white, baked enamel, (.050 in. optional).

Posts - Double slotted galvanized steel logistic posts on 24" centers (16" optional).

Roof - One-piece aluminum (.032 in.), tension-fitted and bonded to roof bows, perimeter riveted. The roof assembly is bolted to the top rail structure for easy removal and repair in case of damage.

Roof Bows - Roll-formed 18 gauge galvanized steel, anti-snag configuration, located on 24" centers.

Rear Frame - 11 gauge (1/8" nominal thickness) galvanneal steel with reinforcement at all stress points. Tapered rear threshold for proper water run-off.

Doors - Custom built side or rear swing doors ensure a precise fit and positive closing, with quality 13mm thick **DuraPlate** exterior skin construction on rear doors and 6mm thick skins on side doors.

Door Hinges - Heavy-duty extruded aluminum side and rear door hinges with replaceable stainless steel pins for the best possible long term use.

Crossmembers - Hi-tensile 3 inch I-beams on 12" centers, (not 16") double bolted with stainless steel fasteners at each end to the heavy-duty extruded aluminum rub rail. Alternating crossmembers are gusseted to longitudinals, and steel wheel pans provide support over the rear wheels.

Longitudinals - Structural steel "C" channel (height dependent on chassis mounting requirements).

Floor - 1 1/8" oak hardwood, each board installed with two 5/16" countersunk screws at each crossmember and securely joined to adjacent boards by shiplap joints and an added crusher bead to ensure a tight seal. The entire floor is coated with two coats of polyurethane varnish.

Lining - 1/4" plywood on sides and front wall.

Interior Light - Roof-mounted dome light with recessed switch mounted inside rear door opening.

Exterior Lights - Marker lights recessed in roof cove with exterior wiring in protective groove. All connectors shielded from moisture by heat-shrink insulators.

Reflectors - Installed as required to comply with FMVSS.

Undercoating - Petrol base (not paint) on full understructure.

Mounting - Body is mounted on customer supplied chassis. Hardwood filler strips are steel-banded to the top of the chassis frame rails. Zinc plated U-bolts are then placed through crush pipes (between frame rails). U-bolts secure the body and crush pipes prevent over-tightening and bending of the frame rails. Structural steel "side-standards" are welded to longitudinals to prevent any side-to-side shifting.

Mudflaps - "U.S. Truck Body" anti-sail premium mudflaps.



Moving Van Specifications

Standard Body Length: 10 ft. – 30 ft. (inside dimension)

Outside Dimension: 6 3/8" longer than inside length

Custom Sizes Available

Standard Width and Height

MODEL	INSIDE DIMENSIONS		OUTSIDE DIMENSIONS		REAR DOOR OPENING	
	Width	Height	Width	Height	Width	Height
MV-96	93"	96"	96"	103"	88"	90.5"
MV-96	99"	96"	102"	103"	94"	90.5"
MV-102	93"	102"	96"	109"	88"	96.5"
MV-102	99"	102"	102"	109"	94"	96.5"
MV-108	93"	108"	96"	115"	88"	102.5"
MV-108	99"	108"	102"	115"	94"	102.5"

Inside width is measured from post to post without lining.

Outside height of body is measured excluding longitudinals.

Rear door openings are the same for roll-up or swing type doors.



U.S. Truck Bodies are Made-to-Order
To Fit Your Chassis:

- Chevrolet** **Kenworth**
- Ford** **Mack**
- Freightliner** **Mitsubishi**
- GMC** **Sterling**
- Hino** **UD**
- International** **Peterbilt**





Moving Van Options

- Translucent Roof
- Interior Roof Lining – Plywood on roof ceiling, 48" center lined or full width
- Interior Lighting – choice of spots or dome lights, multiple locations
- Attics / Peaks – From 24" to 72" deep
- Pre-painted panels or .050 thick white panels
- Graphics installation and custom paint schemes
- Liners – 1/2" plywood, 3/4" plywood, or pre-finished birch plywood
- Side Doors – DuraPlate Construction, double is 72" wide, single is 48" wide, pallet style
- Rear Doors – Roll-up or two panel DuraPlate swing doors with full opening (*illus.*)
- Floors – Logistic track, bull rings, fill and sanded screw holes, upgrade to 1 3/8"
- 48" Pull-Out Tailgate – with ICC bumper (*illus.*)
- ICC Bumper (*illus.*)
- Bumper Step – Open face, close face (*illus.*)
- Aluminum Ramp and Fiberglass Walkboards
- Tool Boxes
- Aluminum Shoring Beams – Logistic straps
- Liftgate Installations – For all makes and models
- Polished Stainless Steel – Front corners, roof radius, rear frame, hinges, and chrome cast front corners
- Wheel Housings or lowest possible floor heights mounting options on chassis
- LED Lights
- Melcher Style Underbody Locking Walkboard Carrier – All sizes of Melcher walkboards

U.S. Truck Body offers many **additional options and customization** upon request. Contact us for your specific needs.

Note: U.S. Truck Body reserves the right to make technical changes for product improvement. Specifications and materials subject to change without notice. Some photos and illustrations may show optional equipment.

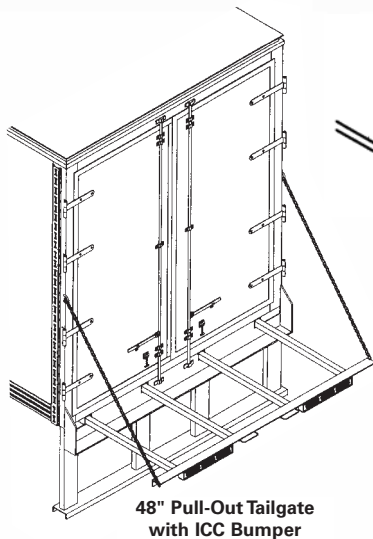

48" Pull-Out Tailgate with ICC Bumper

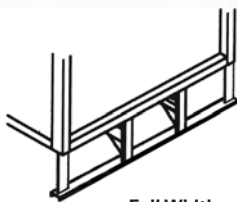

Full Width ICC Bumper

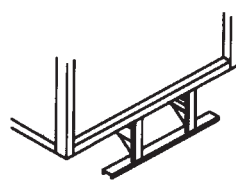

ICC Bumper

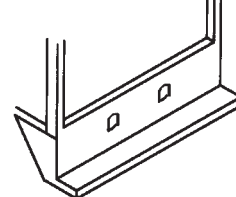

Bumper Step
Open Face
Close Face

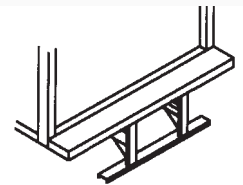

ICC Bumper with Floor Extension
6" & 12"

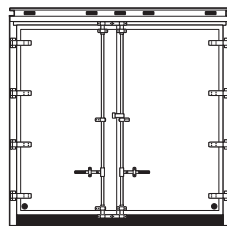

Two-Panel Swing Doors
Full Opening

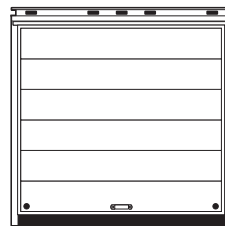

Roll-Up Door



AMSA
AMERICAN MOVING AND
STORAGE ASSOCIATION



NATIONAL TRUCK EQUIPMENT ASSOCIATION



U.S. Truck Body • 1807 N. Bloomington Street • Streator, IL 61364
Phone: 1-800-443-0843 • 1-815-672-3211 • Fax: 1-815-672-1490
www.ustruckbody.com • E-mail: sales@ustruckbody.com